



## **INSTALLATION, OPERATION, & MAINTENANCE MANUAL**



### **MODELS:**

**SDPL-7000 & SDPL-7000XLT  
4 POST LIFT**

**⚠ FOLLOW THIS MANUAL CAREFULLY TO ENSURE THE MACHINE WILL FUNCTION CORRECTLY AND PROVIDE MANY YEARS OF DEPENDABLE SERVICE. FAILURE TO FOLLOW THESE INSTRUCTIONS AND SAFETY WARNINGS MAY RESULT IN PERSONAL INJURY OR PROPERTY DAMAGE. KEEP THIS MANUAL IN A SAFE DRY PLACE FOR FUTURE REFERENCE.**



**TITAN MARKETING, LLC**

PO Box 7069 Greenwood, IN 46142  
1.888.908-4826 FAX (317) 215.2770  
[www.titanlifts.com](http://www.titanlifts.com)

To Our Valued Customers:

Thank you for purchasing a Titan Lifts® product. We hope this high quality equipment provides you with years of dependable service.

It is unfortunate that rare situations may occur with the products you purchase from Titan Lifts®. We value your business as well as the trust you have and need to maintain your relationship with us. Titan Lifts® carries liability coverage that may protect our customers if a situation does occur. However, as in all accidents there must be proof of liability for a claim to be made. Our insurance company requires the following procedures be observed in order to consider a claim:

A. The claimant must contact the Titan Lifts® distributor immediately with the facts of the situation.

B. If any equipment is damaged, including vehicles or shop equipment, Titan Lifts® must be given the opportunity to send an impartial representative to the site for proper assessment of the situation.

C. The Vehicle cannot be moved until either an impartial representative has reviewed the accident or clear and precise pictures are taken that reflect all the pertinent information for an impartial representative to be able to access the information from a distance. Titan Lifts® or its representatives must approve the pictures before anything can be moved.

D. If any potential liability is determined on behalf of Titan Lifts®, two estimates must be submitted for damages to be reimbursed.

It is imperative that the claimant complies with these procedures, because without proper assessment of the situation a claim will be denied.

#### ARBITRATION NOTICE

The installation or use of this equipment shall constitute an acknowledgement that the user agrees to resolve any and all disputes or claims of any kind whatsoever, which relate in any way to the equipment, by way of binding arbitration, not litigation. No suit or legal action may be filed in any state or federal court. Any arbitration shall be governed by the Federal Arbitration Act, and administered by the American Mediation Association, Indianapolis Indiana. The maximum amount that an arbitrator may award and all damages shall not exceed the retail value of this equipment.

#### WARRANTY NOTICE

This equipment must be installed by a "Professional Installer" assembled and used in the manner according to the documentation provided to be covered by warranty.

Damaged or missing components must be reported within 72 hours of receipt to your freight carrier and to the distributor. Claims must be filed to cover cost.

If you have any questions or if we can be of any further assistance, please don't hesitate to contact a Titan Lifts® representative at 1-888-908-4826. Thank you for the opportunity to continue to serve your lift equipment needs.

# CONTENTS

<b>1.Safety .....</b>	<b>1</b>
1.1 Introduction .....	1
1.2 Safety Instructions for Commissioning.....	1
1.3 Safety Instructions for Operation.....	1
1.4 Safety Instructions for Maintenance.....	3
1.5 Risks .....	3
<b>2. Unpacking &amp; set-up .....</b>	<b>4</b>
2.1 Delivery & check of packages .....	4
2.2 Lifting & handling.....	4
<b>3 Specifications .....</b>	<b>5</b>
<b>4 Floor requirement .....</b>	<b>8</b>
4.1 Select the site area .....	8
4.2 Floor Requirements.....	8
<b>5 Installation Instructions .....</b>	<b>9</b>
5.1 Columns and Crossbars.....	9
5.2 Runway Installation .....	9
5.3 Cable Installation.....	10
5.4 Hydraulic Assembly.....	10
5.5 Linkage Assembly .....	11
5.6 Final Adjustments.....	12
<b>6 Operation Instructions.....</b>	<b>12</b>
6.1 Vehicle Loading .....	12
6.2 Raising Lift .....	13
6.2.1 .....	13
6.2.2 .....	13
6.2.3 .....	13
6.3 Lowering Lift.....	13
6.3.1 .....	13
6.3.2 .....	14
6.3.3 .....	14
<b>7 Maintenance.....</b>	<b>15</b>
7.1 Maintenance Schedule.....	15
7.1.1 Daily .....	16
7.1.2 Weekly.....	16
7.1.3 Yearly .....	16
7.1.4 Special Maintenance.....	16
7.2 Maintenance by the Operator.....	17
7.2.1 Hydraulic System .....	17
7.2.2 Greasing Points.....	17
7.2.3 Operational and Wear Checks .....	17
7.2.4 Lift Stability .....	17
7.3 Cleaning .....	18
<b>8 Troubleshooting .....</b>	<b>18</b>
Explosive Drawing.....	20
Parts List .....	22

# **INSTRUCTIONS**

## **1.SAFETY**

### **1.1 INTRODUCTION**



**WARNING:** READ ENTIRE MANUAL AND COMPLY WITH ALL SAFETY AND SERVICE PRECAUTIONS. DEATH, PERSONAL INJURY AND / OR PROPERTY DAMAGE MAY OCCUR IF INSTRUCTIONS ARE NOT FOLLOWED CAREFULLY.

Personal injury and property damage incurred due to non-compliance with these safety instructions are not covered by the product liability regulations.

### **SYMBOLS**

---



**FAILURE TO COMPLY WITH INSTRUCTIONS COULD RESULT IN PERSONAL INJURY.**

---



**FAILURE TO COMPLY WITH INSTRUCTIONS COULD RESULT IN PROPERTY DAMAGE.**

---



**IMPORTANT INFORMATION.**

---

### **1.2 SAFETY INSTRUCTIONS FOR COMMISSIONING**

- The lift may be installed and commissioned by authorized service personnel only.
- The lift may not be installed and commissioned in the vicinity of explosives or flammable liquids, outdoors or in moist rooms (e.g. car wash).

### **1.3 SAFETY INSTRUCTIONS FOR OPERATION**

- Read this entire manual.
- Load should not exceed rated capacity for this lift – 7000lbs
- Indoor use recommended.
- Protect all parts of the electrical equipment from humidity and moisture.
- Only trained authorized personnel over the age of 18 years should operate the lift.
- If an extension cord is necessary, a cord with a current rating equal to or more than that of the equipment should be used. Cords rated for less current than the equipment may overheat.

- Do not operate equipment with a damaged cord or if the equipment has been dropped or damaged - until it has been examined by a qualified service person.
- Maintain a safe working environment. The work area should be clean, dry, clutter free, and sufficiently lit.
- Vehicle doors should be closed during the raising and lowering cycles.
- Closely watch the vehicle and lift during the raising and lowering cycles.
- Do not operate the lift in explosive atmospheres, such as in the presence of flammable liquids, gases, or dust. Power equipment can create sparks which may ignite flammables.
- Keep hands, tools, and other extremities from under carriage and moving parts.
- Never operate this lift with someone on it.
- Do not allow anyone on the lift or inside a raised vehicle.
- Keep children and bystanders away from work area. Do not let children operate or play on lift.
- Wear proper safety attire. Do not wear loose fitting clothing while operating lift. Long hair, jewelry and sleeves should be secured.
- Move the lift only when it is lowered.
- Do not move the lift while loaded. Never leave the lift unattended while under a load that is not in a level safety locked position.
- Do not operate this lift if under the influence of drugs, alcohol, or medication. Operator must be alert at all times when using heavy lift equipment.
- Comply with all applicable accident prevention regulations.
- Only use the vehicle manufacturer's recommended lifting points.
- After positioning the vehicle, apply the parking brake.
- Use caution when removing or installing heavy vehicle components which may result in center-of-gravity displacement.
- Use this lift only for the work it is intended and only use Titan Lifts® recommended attachments. Do not use this product for an application for which it was not designed. Misuse can lead to personal injury and/or property damage.



**WARNING:** Use this lift only in well ventilated areas. Carbon monoxide exhausted from running vehicle engines is a colorless, odorless fume that, if inhaled, can cause serious personal injury or death.



**WARNING:** People with pacemakers should consult their physician(s) before using this product. Operation of electrical equipment in close proximity to a heart pacemaker could cause interference or failure of the pacemaker.



**WARNING:** This product contains or produces a chemical known to the State of California to cause cancer and birth defects (or other reproductive harm). (California Health & Safety Code 25249.5 et seq.)

## 1.4 SAFETY INSTRUCTIONS FOR MAINTENANCE

- Maintenance or repair work should be done by authorized service personnel only.
- Work on the electrical equipment by certified licensed electricians only.
- Ensure that ecologically harmful substances are disposed of only in accordance with the appropriate regulations.
- To prevent the risk of damage, do not use high pressure / steam jet cleaners or caustic cleaning agents.
- Do not replace or override the safety devices.

## 1.5 RISKS



**WARNING:** Risks that personnel could encounter, due to an improper use of the lift, are described in this section.

### **CRUSHING RISK**

During lowering of runways and vehicles, personnel must not be within the area covered by the lowering trajectory. The operator must be sure no one is in danger before operating the lift. Stay clear of the lift when lowering or raising vehicles. Keep hands and feet away from moving parts and especially points that could pinch. Keep your feet clear of the lift when raising and lowering vehicles.

### **BUMPING RISK**

When the lift is stopped at relatively low working height, the risk of bumping against projecting parts increases. Always be aware of your surroundings and avoid bumping your head or body on the lift or the vehicle.

### **TILTING RISK**

Use caution when lowering the lift and make sure the tracks stay level with the safety locks.

## **2. UNPACKING, & SET-UP**

Only skilled personnel who are familiar with the lift and this manual shall be allowed to carry out, lifting, handling, transport and unpacking operations.

### **2.1 DELIVERY AND CHECK OF PACKAGES**

When the lift is delivered, carefully unpack the lift making sure all the parts have been included. Check for possible damages due to transport and storage; verify that what is specified in the confirmation of order is included. In case of damage in transit, the customer must immediately inform the carrier of the problem.

Remove the lift and all parts from delivery pallet and place on a clean, solid, flat surface. Packages must be opened paying attention not to cause damage to people (keep a safe distance when opening straps) and parts of the lift (be careful the objects do not drop from the package when opening).

### **2.2 LIFTING AND HANDLING**

When loading/unloading or transporting the equipment to the site, be sure to use suitable loading (e.g. cranes, trucks) and hoisting means. Be sure to hoist and transport the components securely so that they cannot drop, taking into consideration the package's size, weight and center of gravity and it's fragile parts.

 **WARNING: LIFT AND HANDLE ONLY ONE PACKAGE AT A TIME**

### 3. SPECIFICATIONS



**IMPORTANT: The properties indicated apply to lifts running at operating temperature.**

<b>Specifications</b>	<b>SDPL-7000</b>	<b>SDPL-7000XLT</b>
Center Of Baseplates - Width	100.5" (2553mm)	100.5" (2553mm)
Outside Of Baseplates - Width	112.5" (2858mm)	112.5" (2858mm)
Outside Of Columns - Width	107" (2718 mm)	107" (2718 mm)
Drive-Thru	87" (2210mm)	87" (2210mm)
Between Runways	43.5" (1105mm)	43.5" (1105mm)
Out To Out - Runways	81" (2057mm)	81" (2057mm)
Length of Runway	160" (4064mm)	180" (4572mm)
Width of Runway	18.5" (470mm)	18.5" (470mm)
Total Length of Ramp	37" (940mm)	37" (940mm)
Baseplate Dimensions	12"X12" (305X305mm)	12"X12" (305X305mm)
Column Dimensions	4"X6" (102X152mm)	4"X6" (102X152mm)
Center Of Baseplates - Length	159" (4038mm)	179" (4547mm)
Outside Of Baseplates - Length	171" (4343mm)	191" (4851mm)
Outside Of Columns - Length	165" (4191mm)	185" (4699mm)
Overall Length w/Ramps	201" (5105mm)	221" (5613mm)
Lifting Height	Min 4.5" - Max 68.5" (Min 115mm - Max 1738mm)	Min 4.5" - Max 81" (Min 115mm - Max 2057mm)
Overall Height	84" (2134mm)	94" (2387mm)
Lifting Capacity	7,000 lb	7,000 lb
Net(Gross)Weight	1,680 lb (762 kg)	1,780 lb (807 kg)
Electricity	110V-120V, 60Hz, 3HP/Single Phase, 3 prong power plug, 20AMP	



**IMPORTANT: COMPONENTS AND SPECIFICATIONS ARE SUBJECT TO CHANGE WITHOUT NOTICE.**



# SDPL-7000

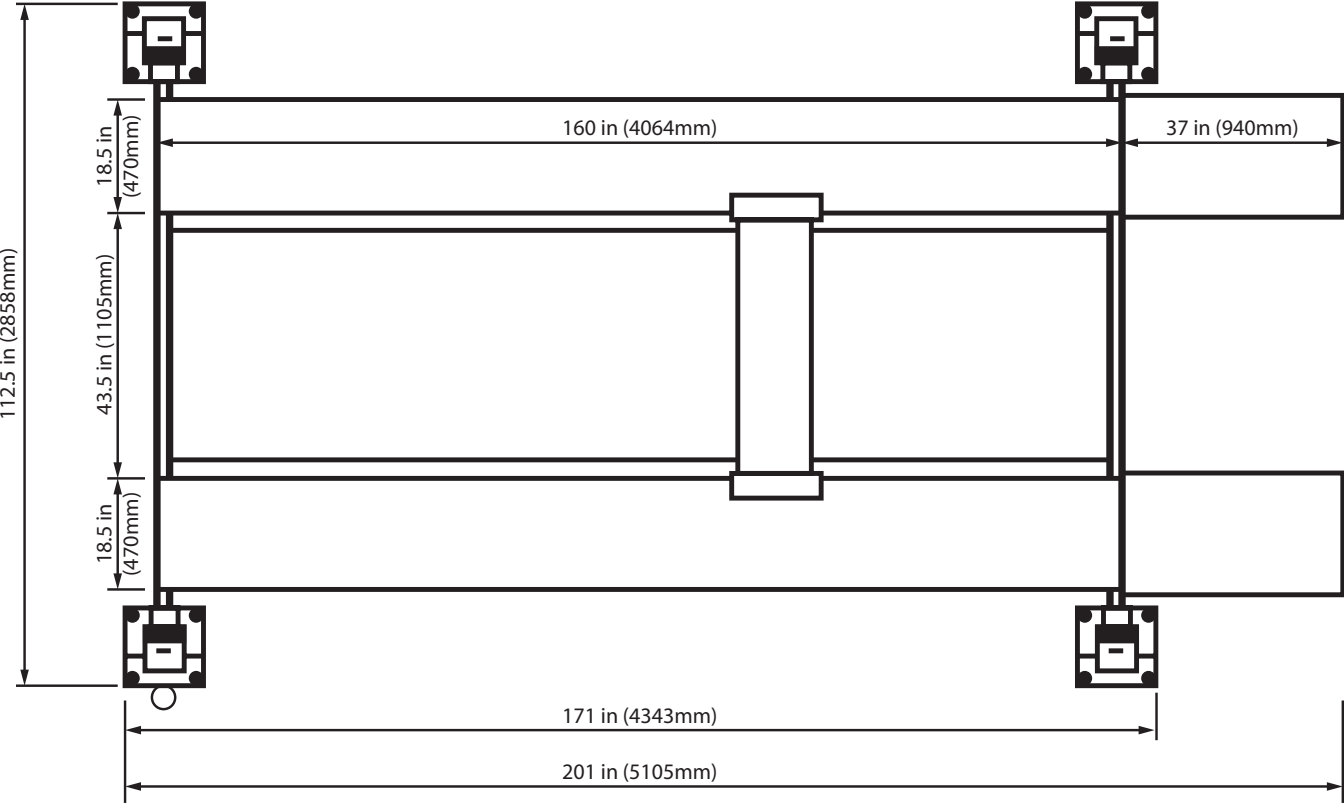
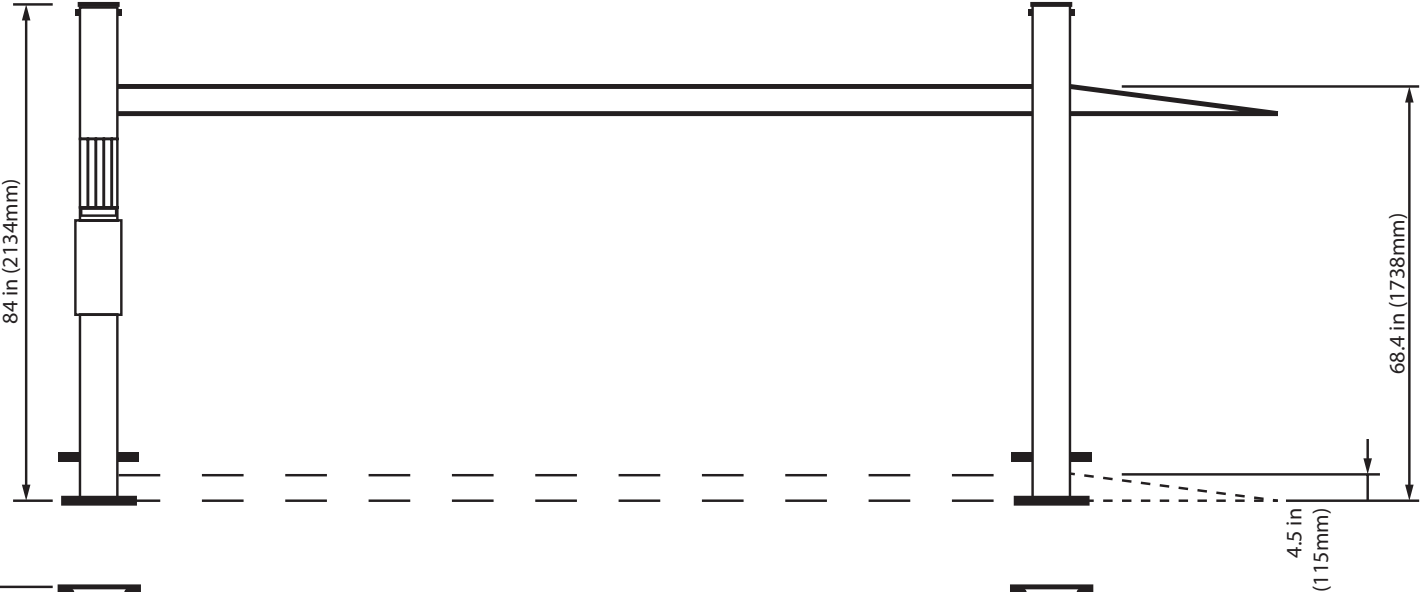

# SDPL-7000XLT

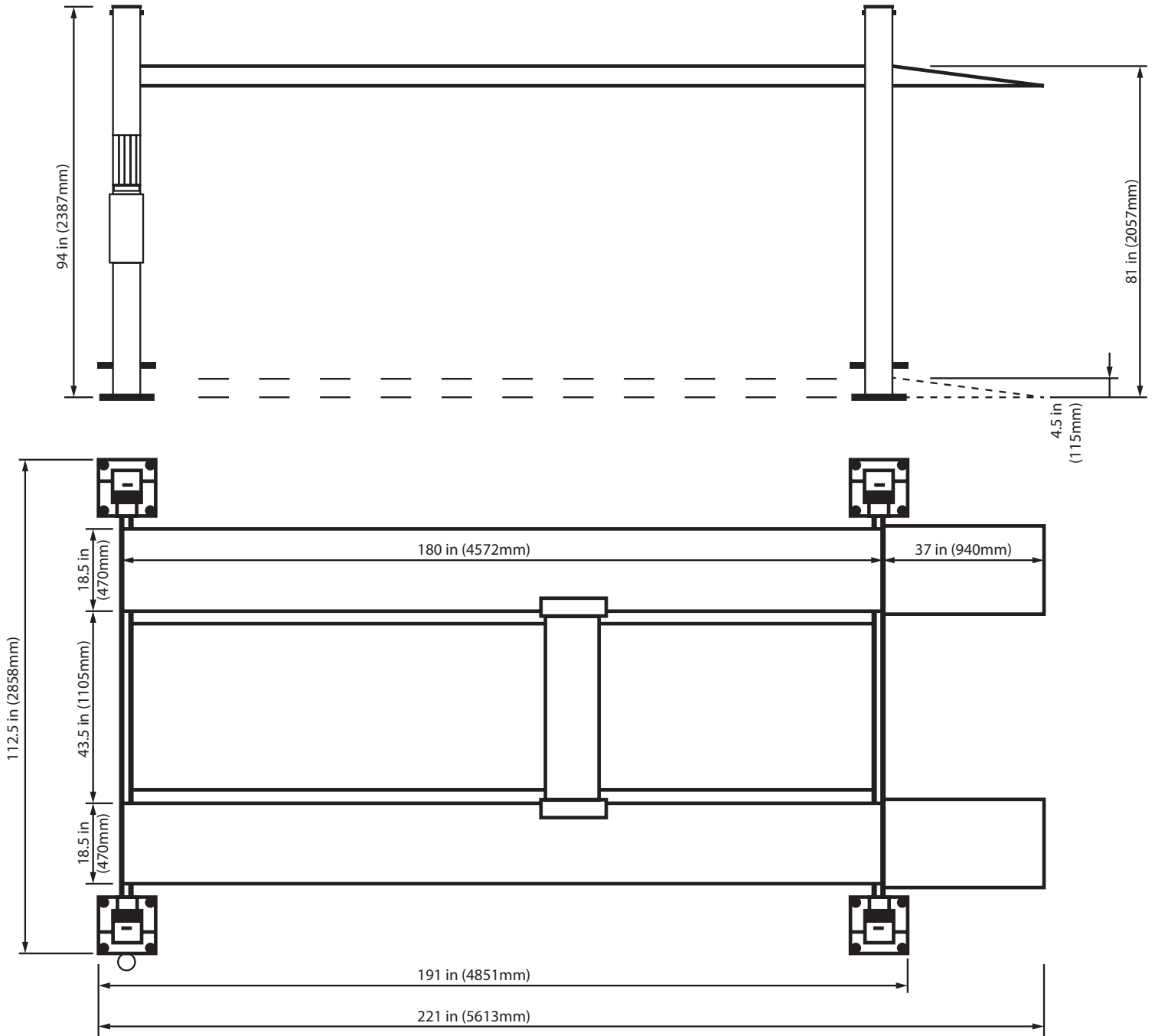

# 4. FLOOR REQUIREMENT

These notes are for your guidance prior to installation.

## 4.1 SELECTING THE SITE AREA

Make sure that adequate space and height is available.

## 4.2 FLOOR REQUIREMENTS

Do not use the lift on any asphalt surface. Make sure the lift is used on a dry, oil/grease free, flat level CONCRETE surface capable of supporting the weight of the lift, the vehicle being lifted, and any additional tools and equipment. The concrete floor surface should have a minimum thickness of 4". The concrete must have a minimum strength of 3,000 PSI, and should be aged at least 30 days prior to use. Do not use the lift on concrete expansion seams or on cracked, defective concrete.



**WARNING: SPECIFICATIONS OF CONCRETE MUST BE ADHERED TO. FAILURE TO DO SO COULD CAUSE LIFT FAILURE RESULTING IN PERSONAL INJURY OR DEATH. THE FLOOR SHOULD BE A REINFORCED CONCRETE SLAB NOT LESS THAN 4" (101.6MM) THICK, COMPRESSIVE STRENGTH OF CONCRETE NO LESS THAN 3,000 PSI (20.68MPA).**



**DANGER: FOR CORRECT INSTALLATION OF THE LIFT, THE FLOOR MUST BE FLAT AND LEVEL. CHECK WITH STRAIGHT EDGE AND LEVEL. IF A FLOOR IS OF QUESTIONABLE SLOPE, CONSIDER A SURVEY OF THE SITE AND/OR THE POSSIBILITY OF POURING A NEW LEVEL CONCRETE SLAB.**



**IMPORTANT: NEW CONCRETE MUST BE ADEQUATELY CURED AT LEAST 30 DAYS MINIMUM. NO LIABILITY FOR ANY DAMAGES WILL BE ACCEPTED SHOULD YOU INSTALL THE LIFT ON AN UNSUITABLE FLOOR.**

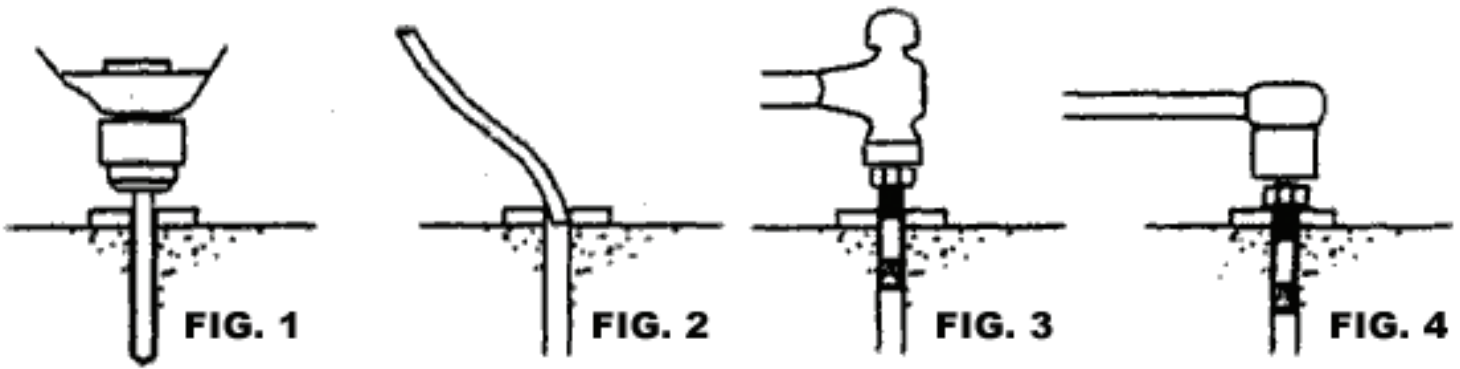

#### 4.4 ANCHORING TIP SHEET

1. Use a concrete hammer drill with a carbide tip, solid drill bit the same diameter as the anchor, 3/4". (.775 to .787 inches diameter). **Do not use excessively worn bits or bits which have been incorrectly sharpened.**
2. Keep the drill perpendicular to the concrete while drilling.
3. Let the drill do the work. Do not apply excessive pressure. Lift the drill up and down occasionally to remove residue to reduce binding.
4. Drill the hole for anchor bolt completely through the concrete. If an error is made during the installation of these anchors, this will allow for the anchor bolt to be driven down into the ground, so that a new anchor may be installed in place (fig.1).
5. **Be sure to clean all dust from hole.** (fig. 2).
6. Place a flat washer and hex nut over threaded end of anchor, leaving approximately 1/4 inch of thread exposed above the nut (fig. 3). Carefully tap anchor into the concrete until nut and flat washer are against base plate. Be sure to only tap the top of the anchor and not the nut. This could cause damage to the threads of the anchor.
7. Tighten the nut (fig. 4) to **80 ft-lbs** of torque (typically this should only be two to three full turns).



**DO NOT USE AN IMPACT WRENCH TO TIGHTEN ANCHORS!**

# 5. INSTALLATION INSTRUCTIONS



**IMPORTANT: BEFORE ATTEMPTING TO ASSEMBLE THIS LIFT TO MAKE SURE THAT THERE IS ENOUGH ROOM FOR ALL COMPONENTS. THE SAFETY ROD ASSEMBLY WILL TAKE UP ADDITIONAL SPACE WHILE BEING INSTALLED. KEEP THE FLOOR AREA CLEAR OF THE LIFT COMPONENTS UNTIL THEY ARE READY TO BE INSTALLED.**

## **5.1 COLUMNS AND CROSSBARS**

1. Locate the four columns and two crossbars. Determine where the power unit is to be placed (front driver side or rear passenger side) and place the column with the bracket in that location. The directions in this guide assume that the power unit will be placed in the front driver side position.
2. Once you have placed the column with the bracket, stand it up with the opening facing in and the lock blocks located on the right side of the column opening (as you stand facing the opening) along the front guide line.
3. Across from it, stand another column in the front passenger side position. Make sure that the opening is facing in towards the front driver side column and the lock blocks are on the left side of the column opening, along the front guide line.
4. With both columns in place, tilt them back until they are lying on the ground and remove the top caps.
5. Position a crossbar at the top of the two columns so that it can be slid into both. Make sure that the spring loaded lock latches at either end of the crossbar are facing up, with bevel side up.



6. Safely slide the crossbar into the top of the columns. In order to lower the cross beam all the way down it will be necessary to manually hold the lock latches out of the way of the stop blocks. Release the latches to engage the lowest lock blocks (16" off the ground). Leave this assembly down until you are ready to install the runways.
7. Repeat process for rear columns and cross beam. Make sure the lock blocks on the rear driver side column are on the left of the column opening along the rear guide line, and that the lock blocks on the rear passenger side column are on the right side of the column opening along the rear guide line. Cross beams should be spaced 156" apart (7000 model) or 176" (7000XLT model) measuring inside-to-inside.

## 5.2 RUNWAY INSTALLATION

1. Before placing the runways, make sure that your column and crossbar assemblies are standing and are set in the proper locations. Also, remember that the ledge running down the side of the ramps will always face one another on the inside.
2. The runway with the cylinder attached to it will be placed next to the column with the bracket for the power unit. The  $\frac{3}{4}$ " hole on the side of the runway should be positioned next to the power unit column. Make sure that you have plenty of lifting power before attempting to place these runways.
3. Lift the ends of the cylinder runway onto the crossbars. Make sure that the holes in the crossbars line up with the hole on the runway and temporarily bolt together using one bolt in each end.
4. Repeat this process for the remaining runway. Remember to keep the ledge running the length of track facing to the inside.
5. Locate the 4 drop-in ramp clips and working on one end at a time, carefully remove the track bolts, install the ramp clip, with spacing collars towards cross beam, and reinstall using both bolts and tighten.

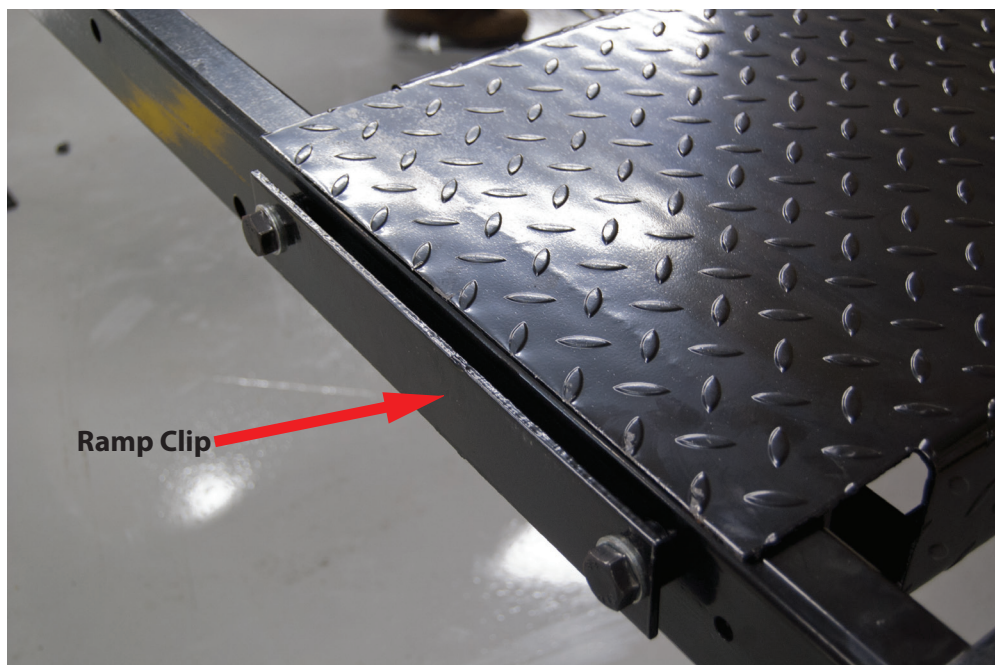

## 5.3 LOCK LINKAGE ASSEMBLY



**IMPORTANT:** This manual covers installing the power column at the driver's side front position.

1. The single point safety lock is a system of connecting rods and linkage that disengage the four lock latches that secure the lift to each column. Locate the 6 rods: 2 long rods, 2 short rods, 1 handle, 1 tee. Ensure lift is far enough from the wall to slide in long rods.
2. Starting with the handle, insure that spacer is installed over threaded end of handle and inset rod into hole on cross bar near power column. Take care to run rod through rod guide located under track.
3. Install long rod into the hole on the cross beam near the driver's rear column. Make sure the spacer is on the rod and take care to run rod through rod guide.
4. Thread nut onto ends of handle rod and "T" rod. With the T on the handle set at 12:00 o'clock and the T on the long rod set at 12:00 when viewed from power unit end, attach coupler and tighten with lock nuts. Rod should be secure but free enough to swing.
5. Starting at the power unit end, attach linkage bolt at one end of the long  $\frac{1}{4}$ " rod into the hole located in the lock latch near the passenger front column and secure with nut. Attach the other end of the long  $\frac{1}{4}$ " rod to the top of the handle T
6. Repeat using short  $\frac{1}{4}$ " rod attaching to the lock latch near the driver's side front column and attach the other end to the bottom of the handle T
7. Repeat process on rear cross beam.



## 5.4 CABLE INSTALLATION

1. Lay out all cables and measure from the inside of the button end to the end of the cable bolt to insure proper cable lengths. See parts list for length and placement of cables.
2. In order to attach the cable buttons to the mounting bracket on the end of the ram, the ram must be extended. Take care not to score the ram when pulling the ram manually or tightening the nut. This will ruin the seal. Since the nub end of the cable is the easier end to feed through the pulley, start with the pulley at the end of the crossbar and work your way back to the ram.
  - a. Using the cable mounting-bracket on the end of the ram, pull the ram out by hand.

3. Install cable buttons into the appropriate slots in thick plate and secure with slots on thin plate. Tighten enough so the nylock nut is fully threaded onto the head of the ram and that at least three threads are exposed past the top of the nut. The cable bracket should still be able to move freely on the ram head.
4. Run the threaded cable ends into the hole in the top caps and secure with washer and nylock nut.

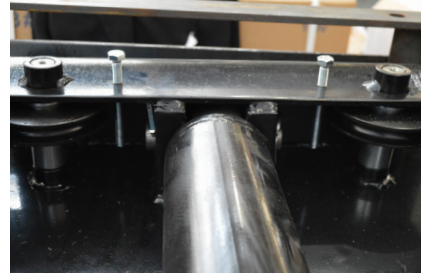

5. After securing the cables, thread the 6 provided bolts into the bottoms of the runways to help prevent any cables from slipping off the pulleys.

**i IMPORTANT:** Make sure the set screws are properly installed in the pins that run through the center of the pulleys under the runway. The dimple in the pin should be aligned with the set screw in order to properly secure the pin into the runway.

## 5.5 HYDRAULIC ASSEMBLY

1. Secure unit to column bracket using provided bolts, washers, lock nuts and nuts.

2. Remove the fitting with the plastic cap (Fig. 1) from the port on the power unit and connect the hydraulic supply hose to the power unit using the supplied coupling (Fig. 2) (Teflon not required). Do not overtighten, backing nut & o-ring will complete the seal.

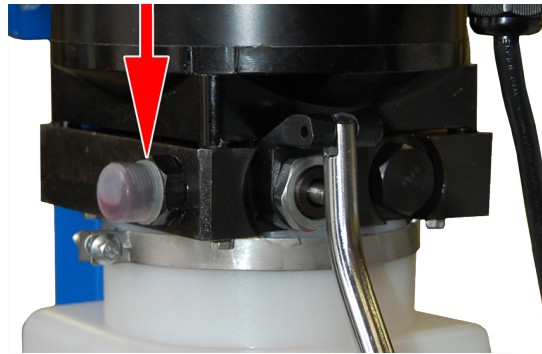

**Fig. 1**

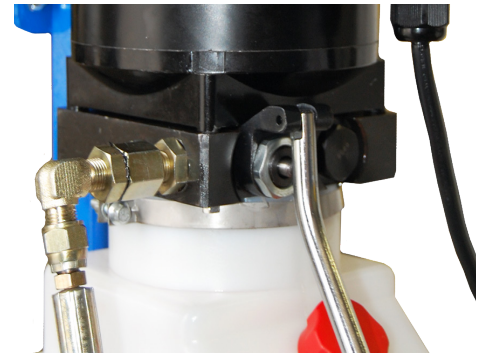

**Fig. 2**

3. On the end of the cylinder hose, located under the runway track (8 & 8.1), remove the backing nut from the bulkhead fitting, insert fitting through hole in the side of the runway track and secure with backing nut. (Fig. 3)
4. Attach loose end of power unit hose to the bulk head fitting. **NOTE:** It may be necessary to remove the hydraulic hose from the 90° fitting and re-install in order to remove any twists in the hose.
5. Fill the oil tank reservoir with hydraulic oil, approximately 1 - 2" below the fill cap. Fill the oil tank with a premium quality ISO-32, AW-32, or AW-46 hydraulic oil, or premium quality ATF DEXRON-III/MERCON.
6. Insure all hydraulic fittings are tight and not leaking.



**Fig. 3**



## 5.6 FINAL ADJUSTMENTS



**IMPORTANT: PRIOR TO PROCEEDING WITH THE FINAL ADJUSTMENTS PROCESS, PLEASE READ OPERATION INSTRUCTIONS IN SECTION 6.**

1. Plug the hydraulic unit into a standard 110V-120V/60Hz AC outlet.
2. Press power up control button (Pg. 13) for 10 seconds. Then while continuing to hold the up control button press the lowering handle (Fig. 4) for another 5-10 seconds, allowing air to be bled from the system.
3. Run power until tracks begin to rise. **NOTE: Never adjust cables with a vehicle on the lift. This will damage threads on cable.**
4. Check to make sure that all cables are in their sheaves.
5. Lower the lift completely until all air has bled, and check the fluid level. Add fluid as needed.
6. Run lift up and down a few times to insure that all components are functioning properly. Have helper check to be sure that far side lock latches are disengaging as fully as the near side lock latches.
7. Run lift up until all lock latches have cleared the top safety block. Measure from bottom of lock latch to top of safety block on each column to find the highest corner of lift. Tighten all other cables until measurement is equal to the highest corner. Lower the lift back down and then up again, checking to hear all 4 lock latches engaging at the same time.

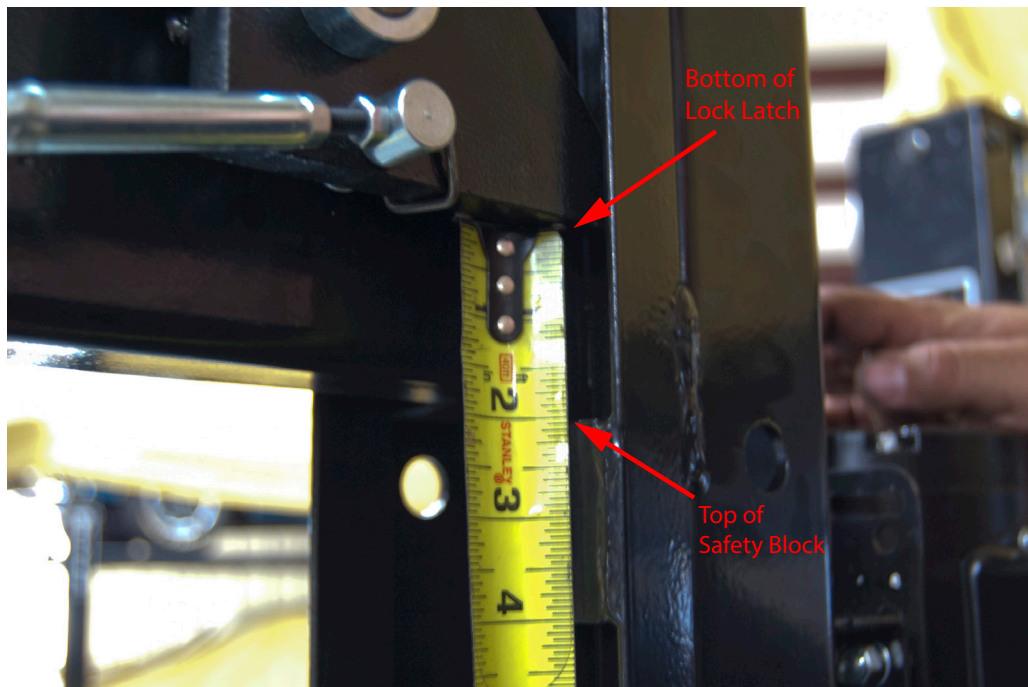

8. With lift all the way down, install the approach ramps and carefully drive a vehicle onto the tracks.
9. Run the lift up and down a few times rechecking all function. If cables need to be adjusted, vehicle must be removed first or damage to threads on cable will occur.
10. Check for any leaks and tighten as necessary.

# 6. OPERATION INSTRUCTIONS



**IMPORTANT: ALWAYS CHOCK WHEELS AND SET PARKING BRAKE BEFORE LIFTING VEHICLE!**



**WARNING: LIFT OPERATION BY TRAINED AUTHORIZED PERSONNEL OVER 18 YEARS ONLY. APPLY THE PARKING BRAKE AFTER POSITIONING THE VEHICLE ON THE LIFT. DO NOT ALLOW ANYONE TO STAY IN LIFT AREA DURING RAISING AND LOWERING CYCLES. CLOSELY WATCH THE VEHICLE AND THE LIFT DURING RAISING AND LOWERING CYCLES. OBSERVE THE RATED LOAD CAPACITY AND LOAD DISTRIBUTION. DO NOT ALLOW ANYONE TO CLIMB ON LIFT OR STAY INSIDE VEHICLE. MAKE SURE THE VEHICLE DOORS ARE CLOSED DURING RAISING AND LOWERING CYCLES.**

## **6.1 DEFECTS / MALFUNCTIONS**



**WARNING: IN CASE OF DEFECTS OR MALFUNCTIONS SUCH AS JERKY LIFT MOVEMENT OR DEFORMATION OF THE SUPERSTRUCTURE, SUPPORT OR LOWER THE LIFT IMMEDIATELY. CONTACT QUALIFIED SERVICE PERSONNEL.**

## **6.2 CONTROLS**

### **6.2.1 UP CONTROL**



Once the up button is pressed, the lift moves up until the button is released or the limit stop is reached.

### **6.2.2 SAFETY LOCK CONTROL**

1. Press and hold the lowering handle (Fig. 4) until the safety lock blocks(30) are engaged to level safety stops on the columns.

### **6.2.3 LOWERING CONTROL**

1. Press the up button enough to make the safety lock blocks disengage the safety stops on the columns. Pull and hold the safety lock release handle (Fig. 5), and then press the lowering handle (Fig. 4) until the lift is completely lowered.



**Fig. 4**

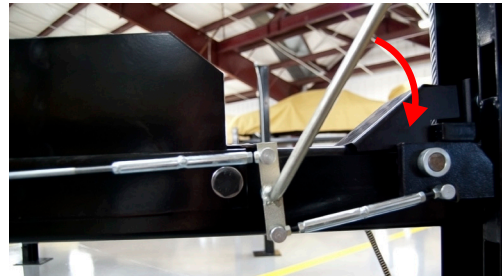

**Fig. 5**

### **6.3.1 VEHICLE LOADING**

1. Make sure front tire stop plates are in place and, position vehicle on lift runways by having another person guide you onto the runways.
2. Check for proper weight distribution (center of gravity should be evenly distributed between columns).
3. Set vehicle parking brake and chock tires to prevent vehicle movement.
4. Use caution before lifting pickup trucks, suv's and other vehicles. The individual axle weight capacity should not exceed 1/2 of lift capacity.
5. Make sure vehicle is neither front nor rear heavy.
6. Make sure to install all front and rear tire stop plates prior to raising the lift with a vehicle.

### **6.3.2 RAISING LIFT**

1. Push the up button to raise lift until platform runways clear the floor.
2. Stop and check for vehicle movement and vehicle weight distribution. If secure raise to desired height.
4. Always lower the lift to the nearest lock position by pressing the lowering handle to relieve the hydraulic pressure and let the safety lock blocks set in a handle locked position.
5. Never work under a lift that is not in a level safety locked position.

### **6.3.3 LOWERING LIFT**

1. Clear all obstacles from under lift and vehicle, and ensure only lift operator is in the lift area.
2. Stay clear of lift and raise the lift off the safety locks.
3. Pull safety lock release handle and press the lowering handle to begin descent.
4. Ensure lift is fully lowered, and remove tire stop plates prior to unloading the vehicle.
5. Make sure to install the ramps.
6. Having another person guide you, carefully unload the lift by driving off of the lift runways.



**WARNING: PAY ATTENTION TO THE LOWERING SPEED OF ALL FOUR CORNERS. MAKE SURE THEY ARE MOVING DOWN AT THE SAME SPEED. STOP LOWERING THE LIFT BY RELEASING THE LOWERING LEVER ON THE POWER UNIT AND MOVING THE LOCK LEVER TO THE LOCK POSITION IF ANY CORNER STOPS MOVING OR IS SLOWER IN DESCENT. ALWAYS LOCK THE LIFT BEFORE GOING UNDER THE VEHICLE. NEVER ALLOW ANYONE TO GO UNDER THE LIFT WHEN RAISING OR LOWERING.**



**IMPORTANT: It is normal for an empty lift to lower slowly - it may be necessary to add weight.**



**WARNING: THE OPERATOR MUST BE TRAINED AND AUTHORIZED TO OPERATE THE LIFT.**



**WARNING: DO NOT GO UNDER VEHICLE UNDER ANY CIRCUMSTANCES WHILE VEHICLE IS BEING LIFTED OR LOWERED.**

# OPTIONAL CASTER KIT



**IMPORTANT: Hitch pin and hairpin clip to attach casters to lift in following steps.**

1. Raise lift 2' - 3' high.
2. Place caster assemblies under crossbeams as shown. Secure with Hitchpin and Hairpin Clip.
3. Lower the lift and the columns will automatically raise off the floor.

**NOTE: After using the caster kit, always check to ensure that all cables are still routed properly and aligned on the pulleys.**

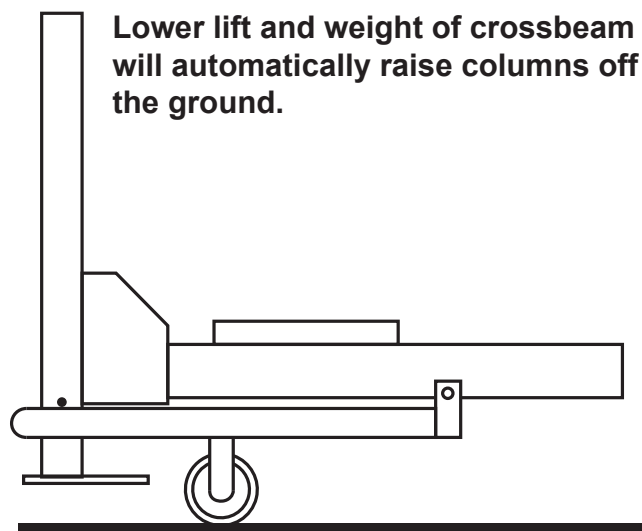
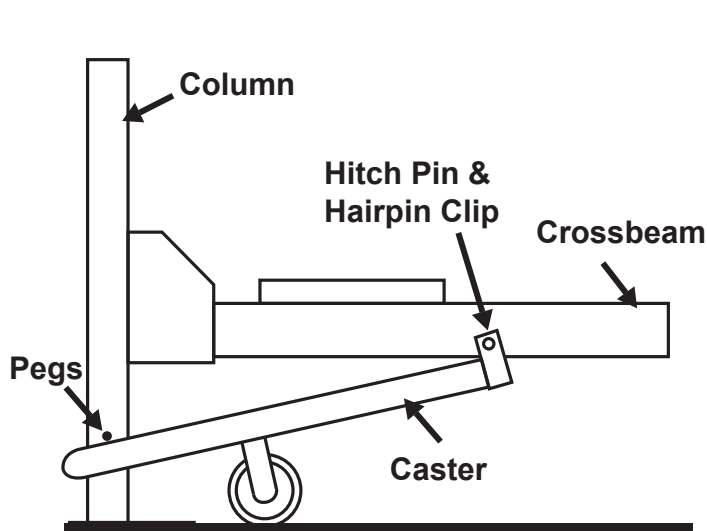

## 7. MAINTENANCE



**WARNING: DISCONNECT THE POWER BEFORE SERVICING THE LIFT.**



**IMPORTANT: THE MAINTENANCE INTERVALS INDICATED BELOW APPLY TO AVERAGE WORKSHOP USE. THE LIFT SHOULD BE INSPECTED MORE FREQUENTLY FOR SEVERE USE APPLICATIONS.**

### **7.1 MAINTENANCE SCHEDULE**

It is important to keep the lift clean, dry, and well maintained by establishing a periodic preventive maintenance program to ensure trouble-free operation and long service life.

### **7.1.1 DAILY**

1. Check safety lock audibly and visually while in operation.
2. Check safety latches for free movement and full engagement with the safety stops on the column.
3. Check hydraulic connections, and hoses for leakage.
4. Check that all cables are routed properly.
5. Check cables for damage, bends, cracks and any loose cable fittings.
6. Check for frayed cables in both raised and lowered position.
7. Check snap rings at all rollers and sheaves.
8. Check bolts, nuts, and screws and tighten if needed.
9. Check wiring & switches for damage.
10. Check floor for stress cracks near columns.
11. Check lubrication on cable sheaves and shafts.

### **7.1.2 WEEKLY**

1. IF LIFT IS ANCHORED TO FLOOR - Check anchor bolts torque to 80 ft-lbs for the ¾" anchor bolts. Do not use an impact wrench to tighten anchor bolts.
2. Check floor for stress cracks near column.
3. Check hydraulic oil level.
4. Check and tighten bolts, nuts, and screws.
5. Check all cable sheaves/assembly for free movement or excessive wear on cable sheave shaft.
6. Check for any locks and tighten as necessary.

### **7.1.3 YEARLY**

1. Lubricate the cables sheave shaft by using grease gun at least once a year after the lift is in service.
2. Check for excessive wear of cable. Replace them if necessary.
3. Change the hydraulic fluid - good maintenance procedure makes it mandatory to keep hydraulic fluid clean. Operating temperature, type of service, contamination levels, filtration, and chemical composition of fluid should be considered. If operating in dusty environment shorter interval may be required.

### **7.1.4 SPECIAL MAINTENANCE TASKS**

**NOTE:** The following items should only be performed by a trained maintenance expert:

1. Replacement of hydraulic hoses.
2. Replacement of cables and sheaves.
3. Replacement or rebuilding air and hydraulic cylinders as required.
4. Replacement or rebuilding pumps / motors as required.
5. Checking of hydraulic cylinder rod and rod end (threads) for deformation or damage.

## 7.2 MAINTENANCE BY OPERATOR

1. All moving parts have been lubricated at the factory and should be re-lubricated before the first use and at least once every six months to prevent damage.

### 7.2.1 HYDRAULIC SYSTEM (FIG. 6)

1. Check the fluid level with the lift fully lowered and add fluid as required. Use premium quality ISO-32, AW-32, or AW-46 hydraulic oil, or premium quality ATF DEXRON-III/MERCON.
2. Visually check all hydraulic hoses and connections for tightness before each use to ensure proper working condition.
3. Lightly oil the cylinder rod at least once every six months or when it becomes dry.



**Fig. 6**

### 7.2.2 GREASING POINTS

Slide Tracks:

The slide tracks should be greased every six months (or more frequently in case of noise generation).

Lightly grease the slide tracks over their whole length using a brush.

### 7.2.3 OPERATION AND WEAR CHECKS.

1. Examine lift for structural cracks, bends, or other signs of damage prior to each use. Do not use this product if worn or damaged.

### 7.2.4 LIFT STABILITY

1. Every six months check the nuts of all bolts for tightness.
2. Retighten them as required.

## 7.3 CLEANING



**DANGER: DO NOT USE HIGH PRESSURE / STEAM JET CLEANERS OR CAUSTIC CLEANING AGENTS.**

**RISK OF DAMAGE!**

- 1. PERIODICALLY WASH OFF AGGRESSIVE SUBSTANCES AND TREAT THE LIFT WITH OIL OR WAX SPRAY.**
- 2. REPAIR THE DAMAGE TO THE PAINTWORK IMMEDIATELY TO PREVENT CORROSION.**

# 8. TROUBLESHOOTING

## 8.1 MOTOR DOES NOT OPERATE

**Failure of the motor to operate is normally caused by one of the following:**

1. Breaker or fuse blown.
2. Faulty wiring connections; call electrician.
3. Defective up button; call electrician for service.

## 8.2 MOTOR FUNCTIONS BUT LIFT WILL NOT RISE

**If the motor is functioning, but the lift will not rise do the following in the order given:**

1. A piece of debris is under check valve. Push handle down and push the up button at the same time. Hold for 10-15 seconds. This should flush the system.
2. Check the clearance between the plunger valve of the lowering handle. There should be 1/16" clearance.
3. Remove the check valve cover and clean ball and seat.



**WARNING:** Failure to properly relieve pressure in the following step can cause injury to personnel. This lift uses ISO Grade 32 or other premium quality grade non-detergent hydraulic oil at a high hydraulic pressure. Be familiar with its toxicological properties, precautionary measures to take, and first aid measures as stated in the Safety Summary before performing any maintenance with the hydraulic system.

4. Oil level too low. Oil level should be just under the vent cap port when the lift is down. Relieve all hydraulic pressure and add oil as required.



### **8.3 OIL BLOWS OUT BREATHER OF POWER UNIT**

**If oil blows out of the breather of the power unit, take the following actions:**

1. Oil reservoir overfilled. Relieve all pressure and siphon out hydraulic fluid until at a proper level
2. Lift lowered too quickly while under a heavy load. Lower the lift slowly under heavy loads.

### **8.4 Motor Hums and Will Not Run**

**If the motor hums but fails to run, take the following actions:**

1. Lift overloaded. Remove excessive weight from lift



**WARNING:** The voltages used in the lift can cause death or injury to personnel. In the following steps, make sure that a qualified electrician is used to perform maintenance.

2. Faulty wiring ..... Call electrician
3. Bad capacitor..... Call electrician
4. Low voltage ..... Call electrician

### **8.5 LIFT JERKS GOING UP AND DOWN**

1. If the lift jerks while going up and down, it is usually a sign of air in the hydraulic system. Raise lift all the way to top and return to floor. Repeat 4-6 times. Do not let this overheat power unit.

### **8.6 OIL LEAKS**

**Oil leaks at the power unit and cylinders are normally caused by the following:**

1. Power unit: if the power unit leaks hydraulic oil around the tank-mounting flange check the oil level in the tank. The level should be two inches below the flange of the tank. A screwdriver can be used as a “dipstick”.
2. Cylinder - Piston Rod: the rod seal of the cylinder is out. Rebuild or replace the cylinder.
3. Cylinder - Vent: the piston seal of the cylinder is out. Rebuild or replace the cylinder.

### **8.7 LIFT MAKES EXCESSIVE NOISE / VIBRATES**

**Excessive noise from the lift is normally caused by the following:**

1. Cross beam ends are rubbing the columns. Readjustment needed.
2. Cylinder too tight, load lift half capacity and cycle up and down a few times to break in. Lift cylinder should quiet down with use. If not contact your Titan Lift Distributor to purchase an Oil Additive.
3. May have excessive wear on cable sheaves or shafts. Replace them.

# LIFT OVERVIEW

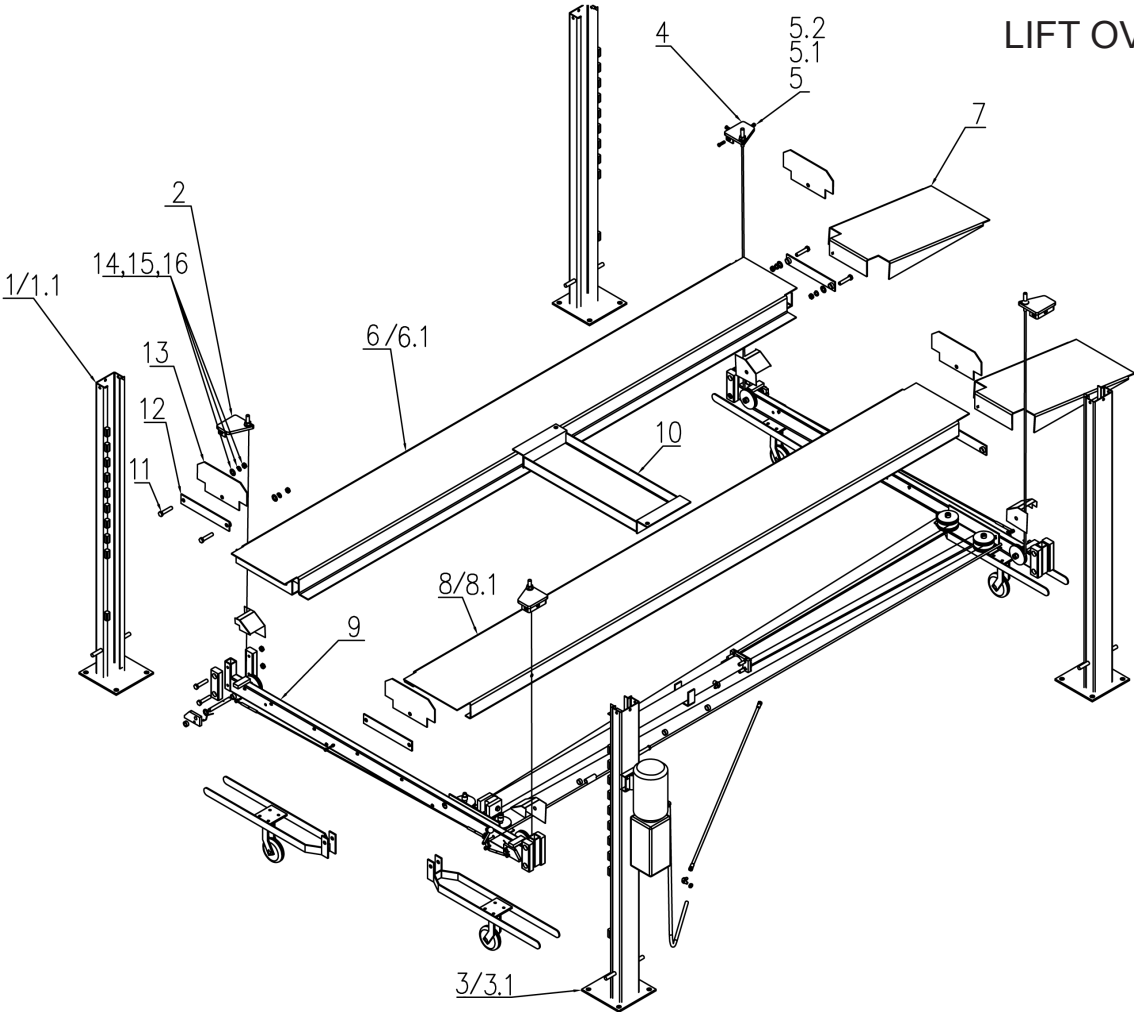

# HYDRAULIC CYLINDER AND CABLE ASSEMBLY

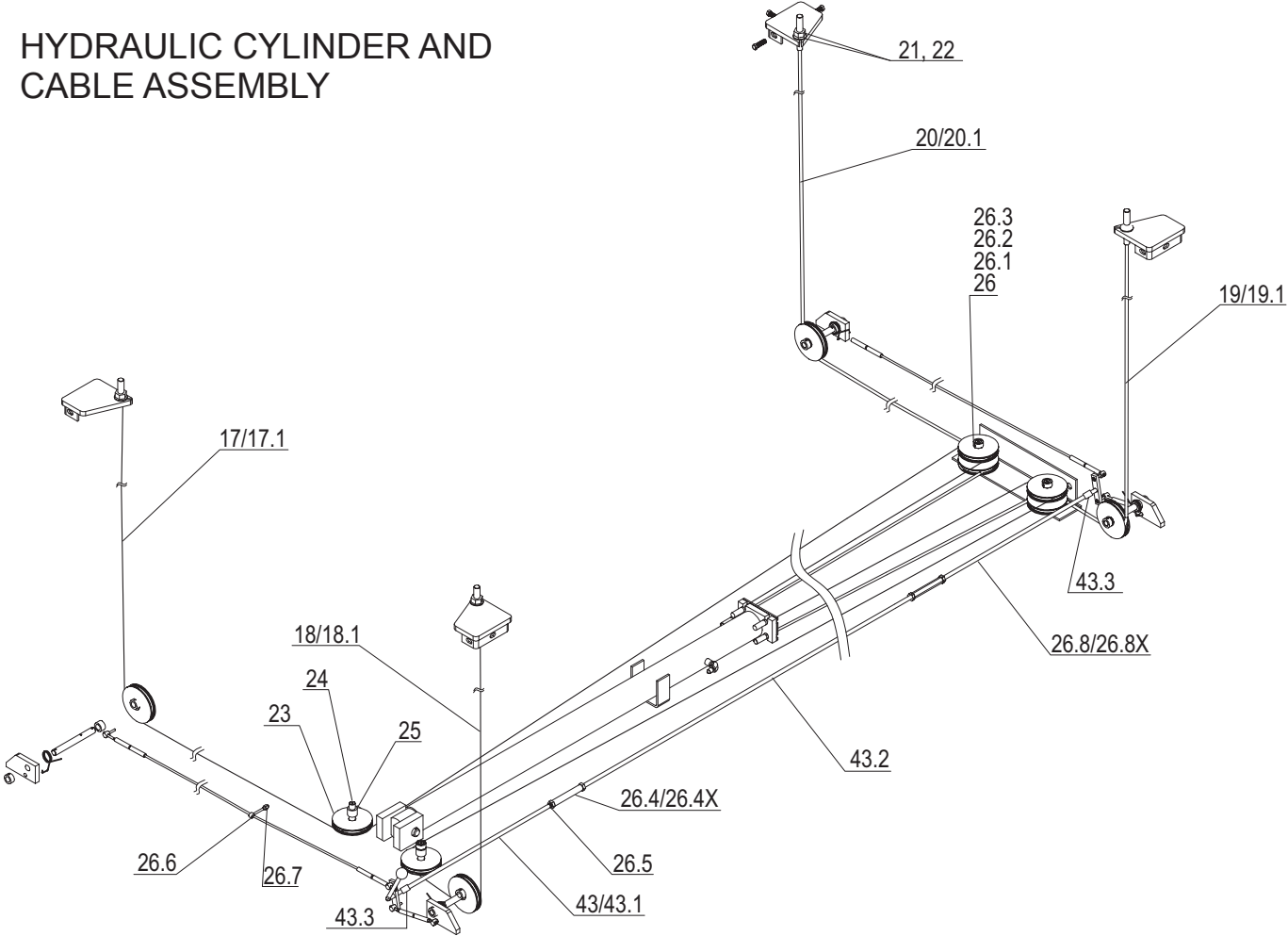

# LOCK ASSEMBLY

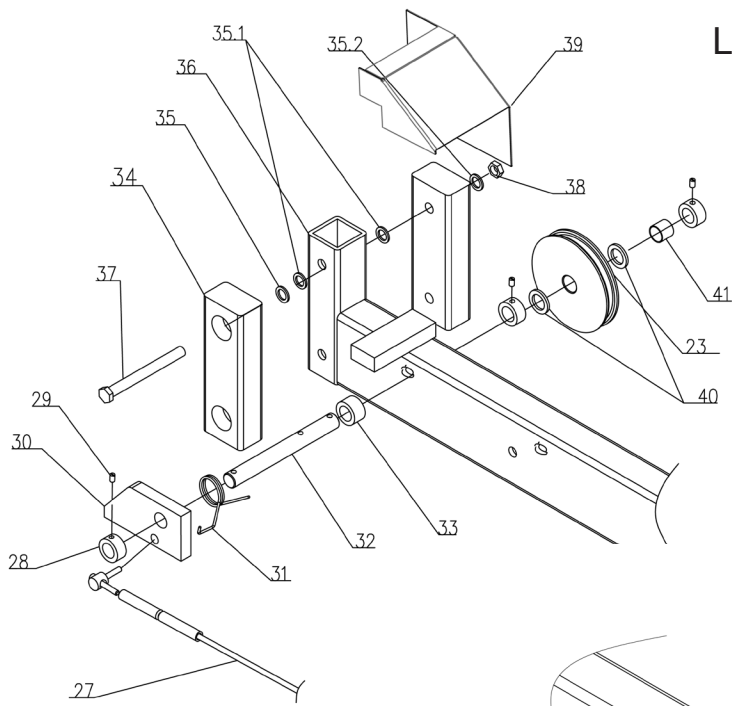

# LOCK HANDLE ASSEMBLY

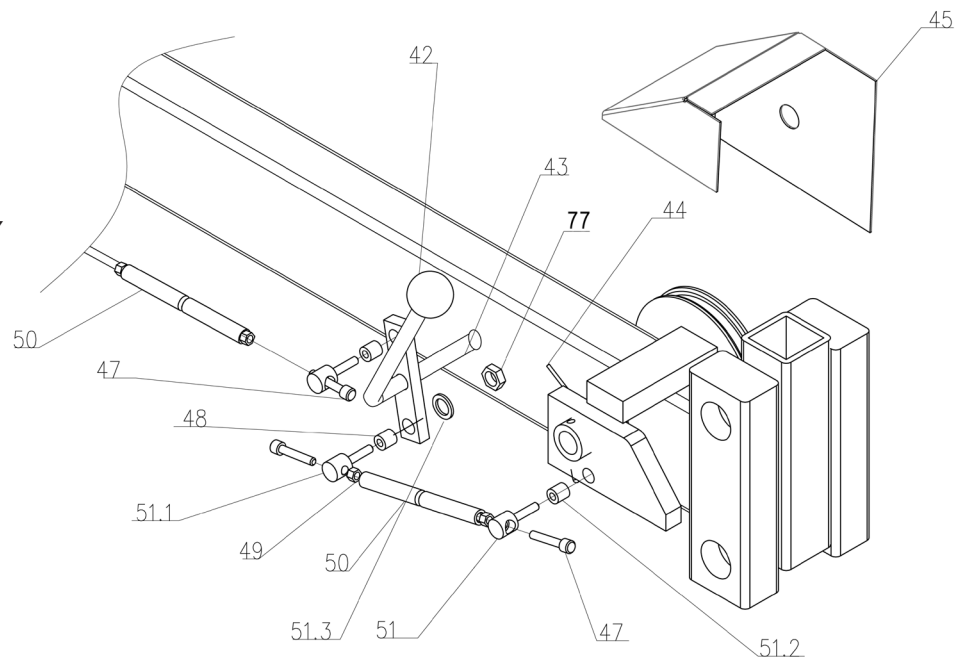

# CASTER ASSEMBLY

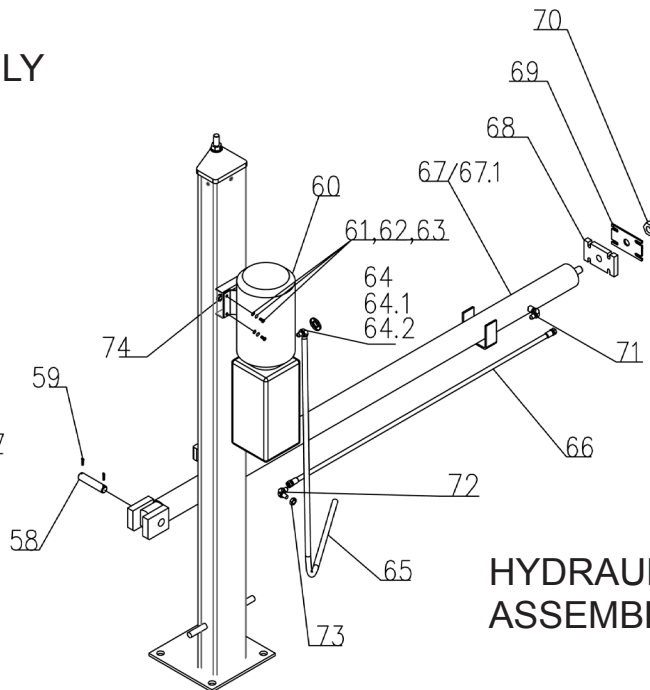
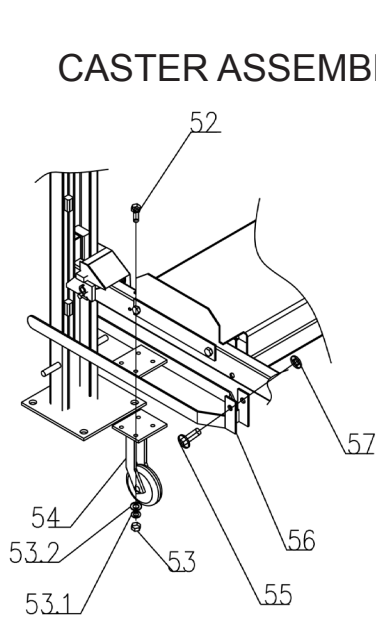

# HYDRAULIC PUMP ASSEMBLY

No.	Description	QTY	No.	Description	QTY
1	Column	3	34	Rubber Block	8
1.1	Column XLT	3	35	Washer - d12	32
2	Top Plate	2	35.1	Flat Washer - d12	16
3	Column - Power Unit Bracket	1	35.2	Flat Washer - d12	24
3.1	Column - Power Unit Bracket XLT	1	36	Cross Beam	2
4	Top Plate	2	37	Galvanized Bolt - M12X120	8
5	Galvanized Bolt - M12X40	12	38	Galvanized Nut - M12	8
5.1	Flat Washer - d12	24	39	Cover A	2
5.2	Galvanized Nut - M12	12	40	Flat Washer - d20	12
6	Runway	1	41	Bushing	4
6.1	Runway XLT	1	42	Brake Lever Ball - M10xφ35	1
7	Ramp	2	43	Lock Handle Rod	1
8	Runway - Cylinder Side	1	43.1	Lock Handle Rod - XLT	1
8.1	Runway - Cylinder Side XLT	1	43.2	Center Safety Rod	1
9	Cross Beam	2	43.3	Outer Safety Rod Bushing	2
10	Jack Tray	1	44	Wrest Spring(Left)	2
11	Bolt - M18X100	8	45	Cover B	2
12	Ramp Clip	4	47	Bolt - M6X35	8
13	Tire Stop Plate	4	48	Short Spacer	4
14	Galvanized Flat Washer - d18	16	49	Galvanized Nut - M6	20
15	Spring Washer (d18)	8	50	Connecting Coupler	6
16	Galvanized Nut - M18	8	51	Long Shaft	4
17	Steel Cable - L=8030mm (316.14")	1	51.1	Short Shaft	4
17.1	Steel Cable - L=8810mm (346.85") XLT	1	51.2	Long Spacer	4
18	Steel Cable - L=6470mm (254.74")	1	51.3	Flat Washer - d8	8
18.1	Steel Cable - L=7250mm (285.43") XLT	1	52	Galvanized Bolt - M10X35	16
19	Steel Cable - L=2590mm (101.96")	1	53	Galvanized Nut - M10	16
19.1	Steel Cable - L=2840mm (111.81") XLT	1	53.1	Spring Washer - d10	16
20	Steel Cable - L=4150mm (163.38")	1	53.2	Flat Washer - d10	16
20.1	Steel Cable - L=4400mm (173.22") XLT	1	54	Caster - φ35	4
21	Lock Nut - 3/4"-16	4	55	Hitch Pin	4
22	Flat Washer - d20	4	56	Caster Frame	4
23	Pulley	10	57	Hair Pin	4
24	Core Shaft	4	58	Hydraulic Cylinder Pin	1
25	Sheath	2	59	Shaft Sheath - φ5x60	2
26	Sheath	2	60	Hydraulic Pump	1
26.1	Flat Washer - d20	6	61	Flat Washer - d8	8
26.2	Bushing	6	62	Spring Washer - d20	4
26.3	Bolt - M6X10	4	63	Galvanized Bolt - M8X15	4
26.4	Large Connecting Coupler	2	64	90 Degree Fitting	1
26.4X	Large Connecting Coupler - XLT	1	64.1	Hydraulic Extension	1
26.5	Galvanized Nut - M12	4	64.2	O-Ring	4
26.6	Bolt - M8X70	2	65	Oil Hose - L=2170mm (85.42")	1
26.7	Galvanized Nut - M8	2	66	Oil Hose - L=1515mm (59.64")	1
26.8	T Safety Rod	1	67	Hydraulic Cylinder - Covers 1850	1
26.8X	T Safety Rod - XLT	1	67.1	Hydraulic Cylinder - Covers 1850 XLT	1
27	Linkage Rod	2	68	Cable Lock Plate	1
28	Sheath	8	69	Cable Lock Plate	1
29	Bolt - M6X10	12	70	Locknut - M24X2	1
30	Safety Lock Block	4	71	90 Degree Fitting	1
31	Wrest Spring(right)	2	72	90 Degree Fitting	1
32	Bushing	4	73	Nut	1
33	Spring Sheath	4	74	Galvanized Nut - M8	8

No.	Description	QTY	No.	Description	QTY
75	Anchor Bolt	16	76	Lockout Pin w/Cotter Pin	4
77	Galvanized Nyloc Nut - M6	8	78	Galvanized Shims	10

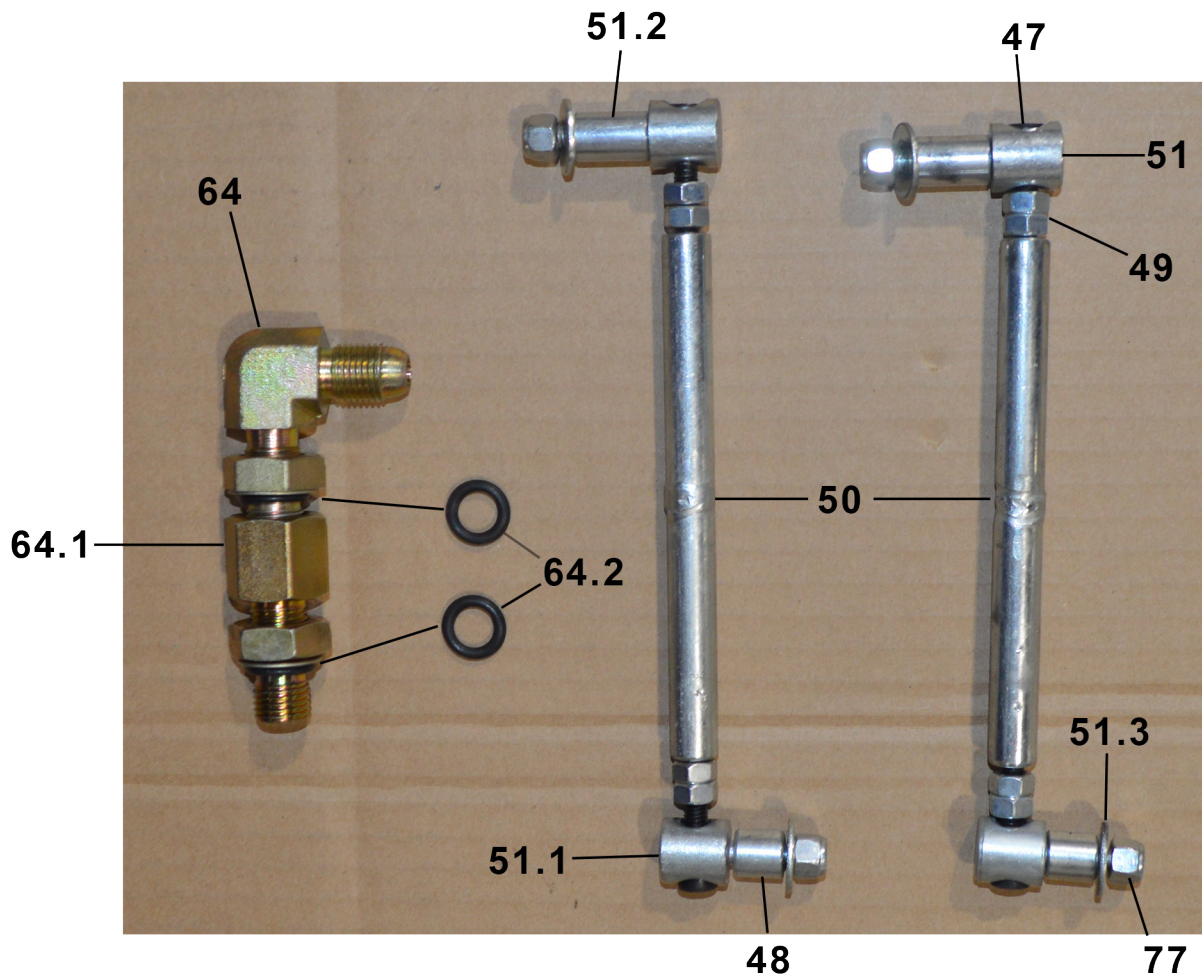
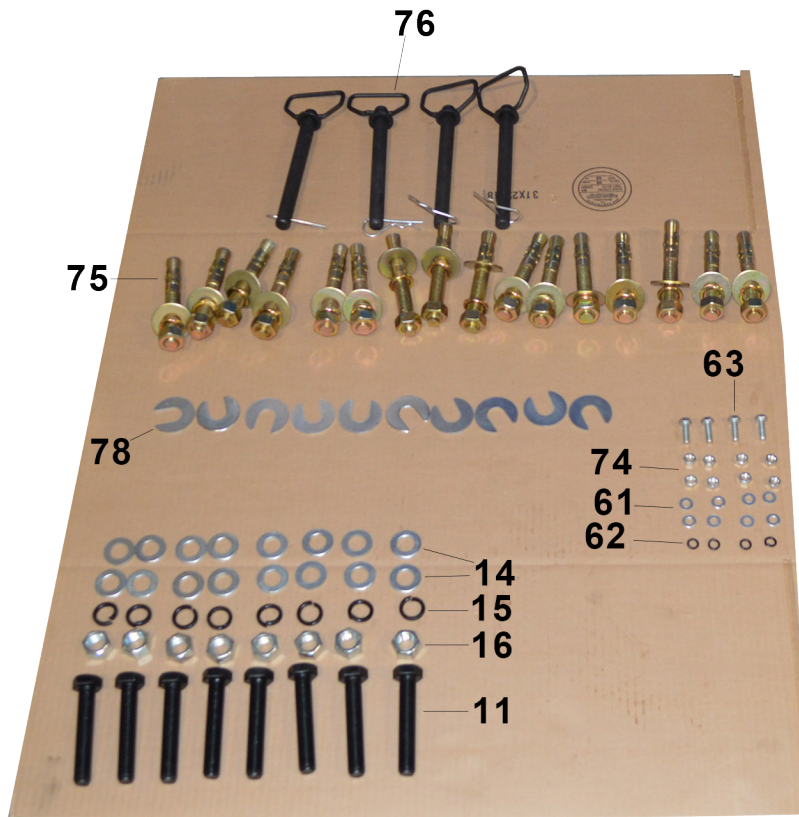

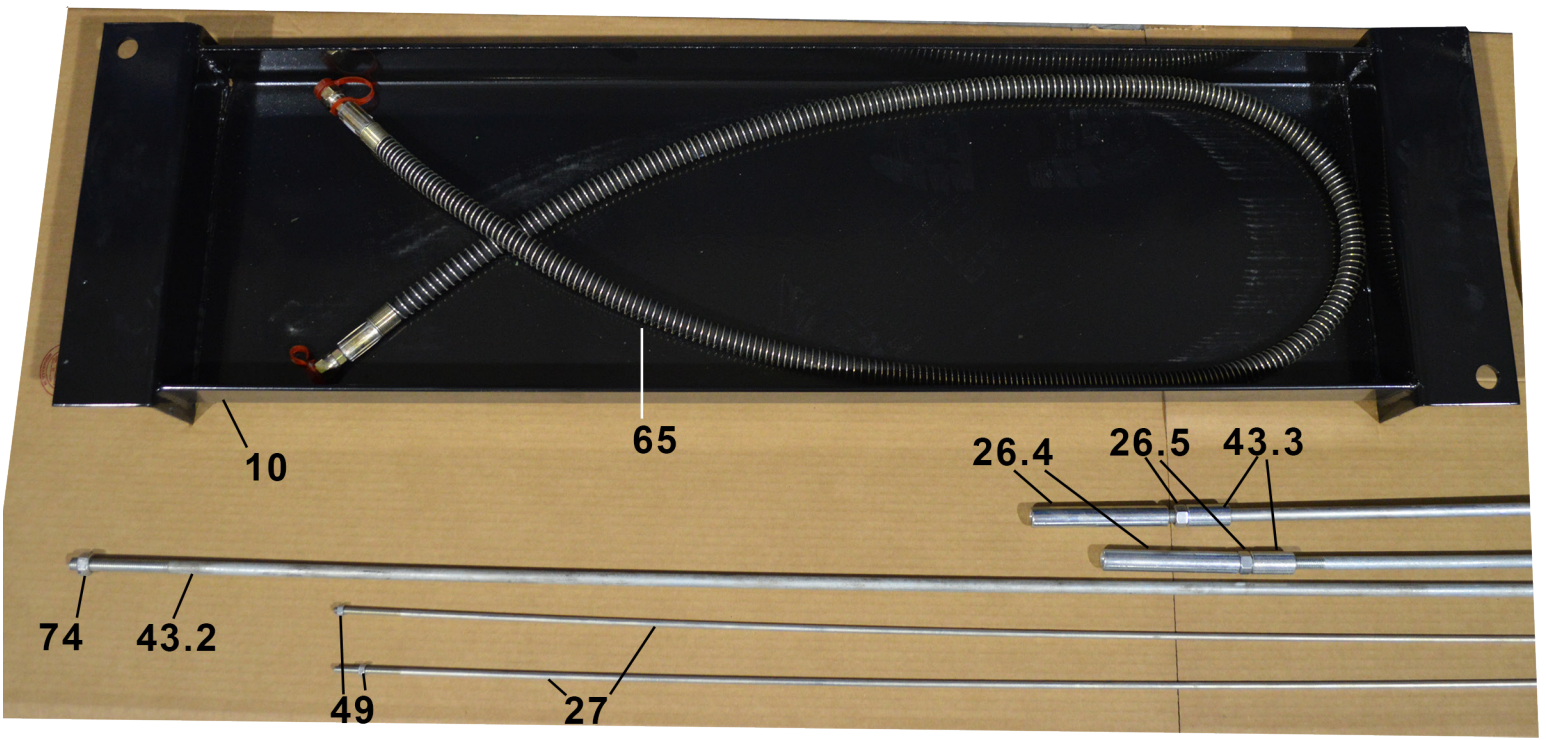
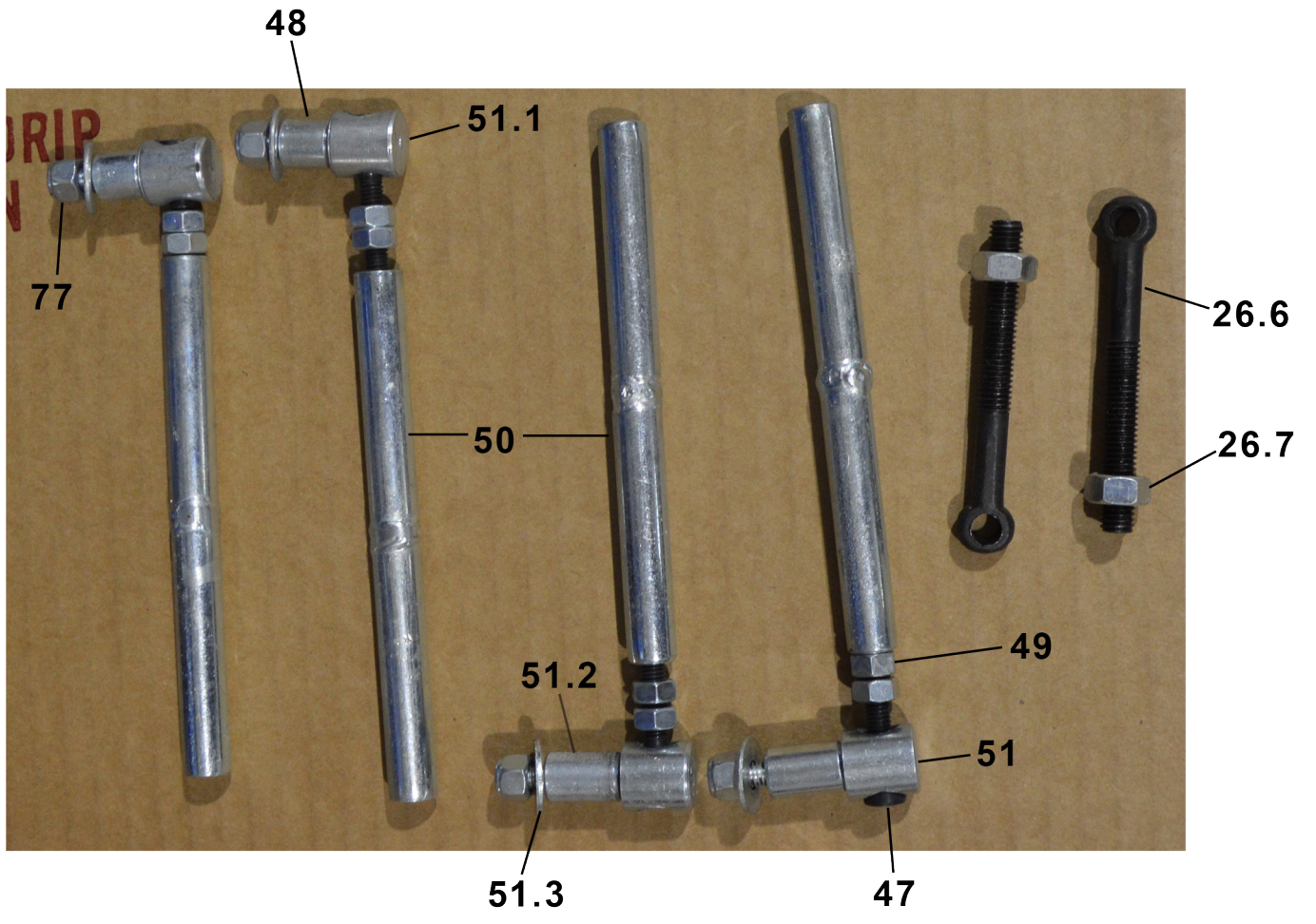

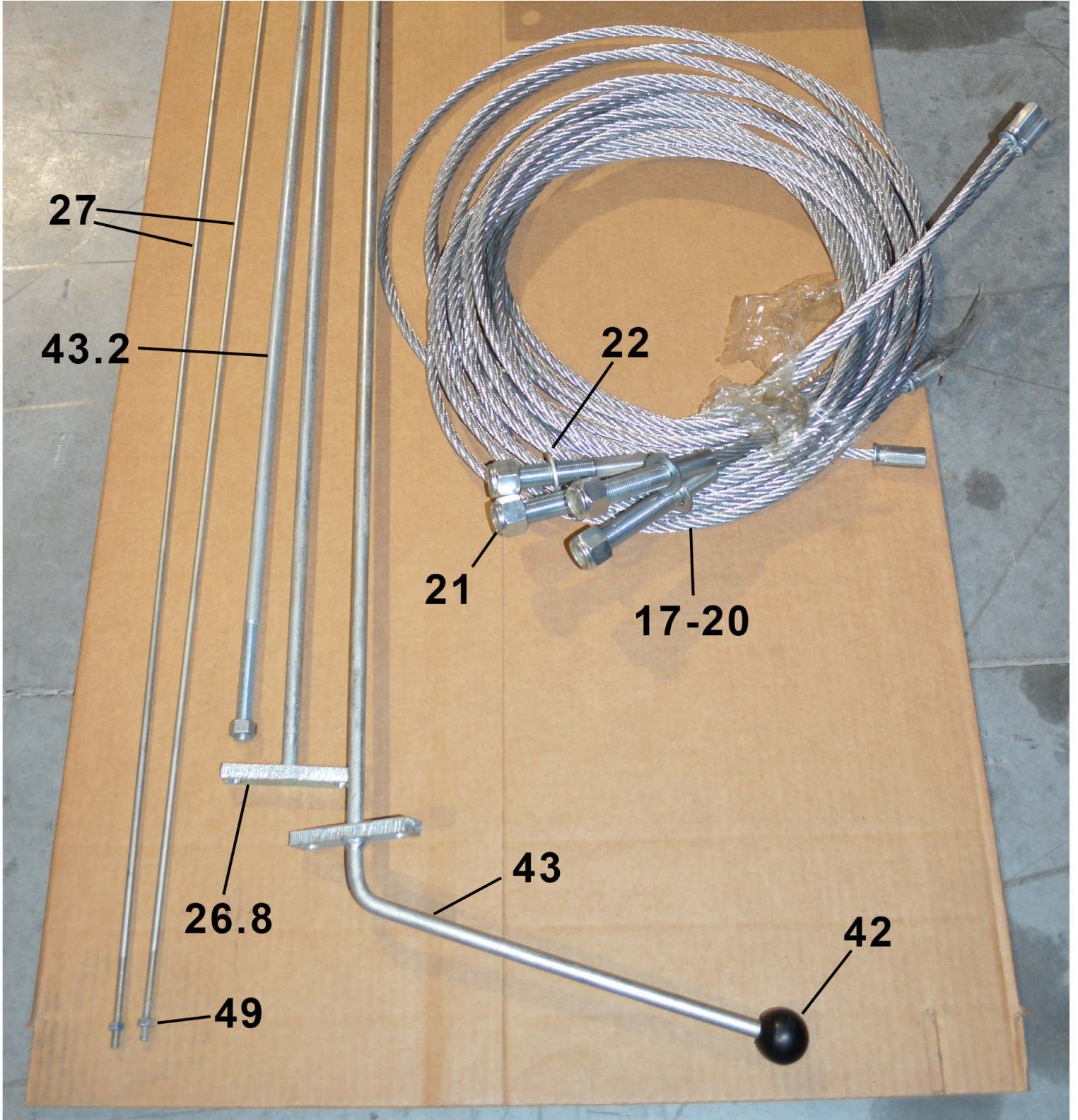











## **LIMITED WARRANTY**

The **Titan 2 Post lifts and 4 Post lifts** are backed by a standard **1 year** replacement parts warranty and a **5 year** structural warranty from the date of purchase, to the original purchaser only. The **1 year** replacement parts warranty covers power units, hydraulic cylinders, and all other assembly components such as, but not limited to: turn plates, slip plates, cables, chains, valves, switches etc. This does not cover normal wear items such as but not limited to rubber lifting pads and nylon slide blocks. Titan **HD2P-9000ACE-D** and **HD2P-9000AFE 2 Post lifts** are backed by a **2 year** replacement parts warranty and a **5 year** structural warranty from the date of purchase, to the original purchaser only. The **2 year** replacement parts warranty covers power units, hydraulic cylinders, and all other assembly components such as, but not limited to: turn plates, slip plates, cables, chains, valves, switches etc. This does not cover normal wear items such as but not limited to rubber lifting pads and nylon slide blocks.

**Titan Mid Rise Scissor lifts** are backed by a standard **1 year** replacement parts warranty and a **5 year** structural warranty from the date of purchase, to the original purchaser only. The **1 year** replacement parts warranty covers power units, hydraulic cylinders, and all other assembly components such as, but not limited to: turn plates, slip plates, cables, chains, valves, switches etc. This does not cover normal wear items such as but not limited to rubber lifting pads and nylon slide blocks.

**Titan Standard Duty and Heavy Duty motorcycle lifts** are backed by a standard **1 year** replacement parts warranty from the date of purchase, to the original purchaser only. The **1 year** replacement parts warranty covers power units, hydraulic cylinders, pneumatic cylinders, and all other assembly components such as, but not limited to: cables, caster wheels, valves, switches, wheel vises etc. This does not cover normal wear items such as but not limited to rubber wheel vise pads.

**Titan Bulldog Moto Cradle Wheel Chock** is warrantied for replacement parts, only to the original purchaser, for a period of **2 years** from the date of purchase.

**Titan shop equipment products and accessories** are warrantied for replacement parts only to the original purchaser for a period of **90 days** from the date of purchase. This **90 day** replacement parts warranty covers products such as but not limited to: EZ mover jacks, Mini Jacks, tie down products, shop and Bulldog Moto Cradle Wheel Chock accessories, dollies, stands, Light Duty Motorcycle Lifts, etc.

For **all** warranty considerations, Titan Marketing, LLC will supply replacement parts only during the warranty period. The original purchaser is responsible for all shipping, handling, and any labor charges incurred. All defective parts must be returned to Titan for inspection and examination. Any parts that are found to be defective will be replaced or repaired to proper working order. Other items not listed above may be considered general wear parts and therefore, will not be covered under warranty. These warranties **do not** extend to **defects** caused by ordinary wear, abuse, misuse, shipping damage, improper installation, voltage or lack of required maintenance. Titan Marketing, LLC is **not** to be held responsible for any **failure** that results from an accident, purchaser/operator abuse, neglect, or failure to operate products in accordance with instructions provided in the owner's manual(s) supplied. Damage caused by rain, excessive humidity, corrosive environments or other contaminants are not covered under warranty. **THESE WARRANTIES DO NOT EXTEND TO ANY COSMETIC DEFECT NOT INTERFERING WITH EQUIPMENT FUNCTIONALITY OR ANY INCIDENTAL, INDIRECT, OR CONSEQUENTIAL LOSS, DAMAGE, OR EXPENSE THAT MAY RESULT FROM ANY DEFECT, FAILURE OR MALFUNCTION OF A TITAN MARKETING LLC PRODUCT OR THE BREACH OR DELAY IN PERFORMANCE OF THE WARRANTY.**



## **WARNING**



The warnings, precautions and instructions in this manual cannot cover all possible conditions and situations that may occur. The operator must understand that the operator must supply common sense and examine caution factors when using this product to determine safety in all circumstances being used.



**TITAN MARKETING, LLC**

PO Box 7069 Greenwood, IN 46142  
1.888.908-4826 FAX (317) 215.2770  
[www.titanlifts.com](http://www.titanlifts.com)

**Patent No.: US 8,104,588 B2  
CA 2,729,670**

**Revision 2**